



FORCE
Certification



OIML Member State

Denmark

OIML Certificate No.

R49/2013-A-DK2-25.01 Revision 2

OIML CERTIFICATE ISSUED UNDER SCHEME A

OIML Issuing Authority

Name: FORCE Certification A/S
Address: Park Allé 345, 2605 Brøndby, Denmark
Person responsible: Lars Poder

Applicant

Name: Siemens AG
Address: DE – 76181 Karlsruhe, Germany

Manufacturer

Name: Siemens SAS
Address: 1 Chemin de la Sandlach
67506 Haguenau Cedex, France

Name: Siemens Sensors and Communication Ltd.
Address: 117, Guangxian Road, Qi Xian Ling, High-Tech Industry Zone,
116023 Dalian, China

Identification of the certified type *(the detailed characteristics will be defined in the additional pages)*

Water meter, type FM320 consisting of FMS300 and FMT020

Designation of the module *(if applicable)*

-

This OIML Certificate attests the conformity of the above identified type (represented by the sample(s) identified in the OIML type evaluation report) with the requirements of the following Recommendation of the International Organization of Legal Metrology (OIML):

OIML R 49, Edition (year): 2013

For accuracy class (if applicable): 1 and 2

This OIML Certificate relates only to metrological and technical characteristics of the type of measuring instrument covered by the relevant OIML Recommendation identified above.

This OIML Certificate does not bestow any form of legal international approval.

The conformity was established by the results of tests and examinations provided in the associated reports:

- Performance tests: 124-30210-1_Type evaluation report - Siemens AG - OIML R 49-2 tests of FM320 water meter version 2
- Environmental tests: 124-31871-1 - Test report - Siemens AG - OIML R 49-2 tests of FM320 water meter

The technical documentation relating to the identified type is contained in documentation file:
Internal FORCE Technology file folder no. 124-30210 and 124-31871

OIML Certificate History

| Revision No. | Date | Description of the modification |
|--------------|-----------------|--|
| Revision 0 | 7 July 2025 | Original certificate |
| Revision 1 | 1 December 2025 | Addition of more meter sizes |
| Revision 2 | 21 April 2026 | New label examples and minor editorial changes |

Identification, signature and stamp
The OIML Issuing Authority

Date: 21 April 2026



Michael Møller Nielsen
Certification manager

Important note: Apart from the mention of the Certificate's reference number and the name of the OIML Member State in which the Certificate is issued, partial quotation of the Certificate and of the associated OIML type evaluation report(s) is not permitted, although either may be reproduced in full.

Measuring system description

The operating principle of this electromagnetic water meter FM320 is that a constant pulsed DC electrical current through the coil circuit results in a magnetic field through the sensor bore with direction from coil to coil. When a conductive liquid passes through the magnetic field a differential DC voltage is induced between the measuring electrodes, and this voltage is proportional to the fluid velocity (Faraday's Law).

FM320 is designed to meet the requirements in ground water, drinking water, wastewater, sewage, or sludge applications. It can be used in test lines for water supplies. For OIML R 49, the product can be used only for cold potable water and hot water (according to OIML R 49).

The design consists of following 17 sizes:

DN25, DN32, DN40, DN50, DN65, DN80, DN100, DN125, DN150, DN200, DN250, DN300, DN350, DN400, DN450, DN500 and DN600.

Please see "Operating Instructions" for more details about the dimensions.



Photo of FM320

Flow designations

The tables below show the sensor variants that have been approved based on the type approval tests performed.

Other sensor variants are also covered by this approval provided the following is fulfilled:

- "R" (Q_3/Q_1) shall not exceed the values in the tables and shall be chosen from OIML R 49-1:2013 list 4.1.4
- Q_3 shall not exceed the values in the tables and shall be chosen from OIML R 49-1:2013 list 4.1.3
- Q_1 shall be larger than the values in the tables
- Q_2 shall be larger than the values in the tables

Class 2:

| SIZE | DN25 (1") | DN32 (1¼") | DN40 (1½") | DN50 (2") | DN65 (2½") | DN80 (3") | DN100 (4") | DN125 (5") | DN150 (6") |
|---------------------------|--------------|---------------|---------------|--------------|---------------|--------------|---------------|---------------|---------------|
| "R" Q_3/Q_1 | 400 | 400 | 400 | 400 | 400 | 400 | 400 | 400 | 400 |
| Q_1 [m ³ /h] | 0.04 | 0.063 | 0.1 | 0.16 | 0.25 | 0.4 | 0.63 | 1 | 1.6 |
| Q_2 [m ³ /h] | 0.064 | 0.1 | 0.16 | 0.25 | 0.4 | 0.64 | 1 | 1.6 | 2.5 |
| Q_3 [m ³ /h] | 16 | 25 | 40 | 63 | 100 | 160 | 250 | 400 | 630 |
| Q_4 [m ³ /h] | 20 | 31.25 | 50 | 78.75 | 125 | 200 | 312.5 | 500 | 787.5 |

| SIZE | DN200 (8") | DN250 (10") | DN300 (12") | DN350 (14") | DN400 (16") | DN450 (18") | DN500 (20") | DN600 (24") |
|---------------------------|---------------|----------------|----------------|----------------|----------------|----------------|----------------|----------------|
| "R" Q_3/Q_1 | 400 | 400 | 400 | 400 | 400 | 400 | 400 | 400 |
| Q_1 [m ³ /h] | 2.5 | 4 | 4 | 6.3 | 10 | 10 | 15.8 | 15.8 |
| Q_2 [m ³ /h] | 4 | 6.4 | 6.4 | 10 | 16 | 16 | 25.2 | 25.2 |
| Q_3 [m ³ /h] | 1000 | 1600 | 1600 | 2500 | 4000 | 4000 | 6300 | 6300 |
| Q_4 [m ³ /h] | 1250 | 2000 | 2000 | 3125 | 5000 | 5000 | 7875 | 7875 |

Class 1:

| SIZE | DN25 (1") | DN32 (1¼") | DN40 (1½") | DN50 (2") | DN65 (2½") | DN80 (3") | DN100 (4") | DN125 (5") | DN150 (6") |
|---------------------------|--------------|---------------|---------------|--------------|---------------|--------------|---------------|---------------|---------------|
| "R" Q_3/Q_1 | 200 | 200 | 200 | 200 | 200 | 200 | 200 | 200 | 200 |
| Q_1 [m ³ /h] | 0.08 | 0.125 | 0.2 | 0.32 | 0.5 | 0.8 | 1.25 | 2 | 3.15 |
| Q_2 [m ³ /h] | 0.128 | 0.2 | 0.32 | 0.5 | 0.8 | 1.28 | 2 | 3.2 | 5 |
| Q_3 [m ³ /h] | 16 | 25 | 40 | 63 | 100 | 160 | 250 | 400 | 630 |
| Q_4 [m ³ /h] | 20 | 31.25 | 50 | 78.75 | 125 | 200 | 312.5 | 500 | 787.5 |

| SIZE | DN200 (8") | DN250 (10") | DN300 (12") | DN350 (14") | DN400 (16") | DN450 (18") | DN500 (20") | DN600 (24") |
|---------------------------|---------------|----------------|----------------|----------------|----------------|----------------|----------------|----------------|
| "R" Q_3/Q_1 | 200 | 200 | 200 | 400 | 400 | 400 | 400 | 400 |
| Q_1 [m ³ /h] | 5 | 8 | 8 | 6.3 | 10 | 10 | 15.8 | 15.8 |
| Q_2 [m ³ /h] | 8 | 12.8 | 12.8 | 10 | 16 | 16 | 25.2 | 25.2 |
| Q_3 [m ³ /h] | 1000 | 1600 | 1600 | 2500 | 4000 | 4000 | 6300 | 6300 |
| Q_4 [m ³ /h] | 1250 | 2000 | 2000 | 3125 | 5000 | 5000 | 7875 | 7875 |

Orientation requirements:

- The meter can be installed in all orientations up to DN300.
- The meter can be installed in horizontal and vertical orientation from DN350 up to DN600.

Sensitivity class:

- The meter requires 0xD straight pipe upstream from the sensor
- The meter requires 0xD straight pipe downstream from the sensor

Other information

The meter is approved for forward metering but is also designed to be used in reverse.

The meter complies with OIML R49:2013 Annex B “Checking facilities - Type P”.

Ancillary devices (§4.3.6 – OIML R 49-1): HART, PROFINET, MODBUS and ETHERNET IP. Where national regulations permit, the remote reading ancillary device may be used for testing and verification and for remote reading of the water meter. It has been proven during the type-examination tests, that the addition of these devices does not alter the metrological characteristics of the meter.

Pressure, pressure loss and temperature ranges

Pressure:

Even if the pressure rating of the flange is designed to reach higher pressure, the MAWP of FM320 product is limited at 40 bar for OIML R 49 certified products. The maximum admissible working pressure is printed on the label for the minimum and for the maximum media temperatures.

Temperature class:

FM320 is qualified for T30 and T50 temperature classes.

Pressure loss class:

FM320 is qualified for Δp_{10} class.

Climatic environments

Environmental class:

Ambient temperature class chosen for OIML is -25°C...+55°C/ condensing. This range will be limited to -20°C ...+55°C due to material properties of the sensor.

Mechanical class:

M1: This class applies to instruments used in locations with vibration and shocks of low significance, e.g. for instruments fastened to light supporting structures subject to negligible vibrations and shocks transmitted from local blasting or pile-driving activities, slamming doors, etc. M1 is equivalent to B and O for OIML R 49.

Electromagnetic class:

E2: This class applies to instruments used in locations with electromagnetic disturbances corresponding to those likely to be found in other industrial buildings.

Protection class

The product can be IP67 or IP68.

Compact/remote

The product can be equipped with cable lengths up to 500 m

Power supply

100 – 240 VAC, 50 – 60 Hz, 25 VA
12 – 42 VDC, 12 W (24 VDC nominal)

Software

Designed according to

- WELMEC Guide 7.2:2023 – with editorial changes
- OIML R 49-1:2024 Annex D “Requirements for software-controlled water meters”

Inscriptions

The water meter FM320 shall be clearly and indelibly marked with the following information:

- System designation
- Manufacturer designation or logo
- Manufacturer postal address
- Type, production year and serial number
- Accuracy class
- Max pressure loss
- Mechanical and electromagnetic environment classes
- Climatic class
- Flow limits
- Sensitivity velocity field classes
- Temperature of medium
- Maximum working pressure
- Supply voltage
- Protection class
- Dynamic Range (Q3/Q1)
- Software version
- Direction of flow by means of an arrow

Labelling examples

Sensor labels

| | | | | | |
|---------------------------------|------------------------|----------|-----------------|-------------|-------|
| SIEMENS | | | SITRANS FMS300 | | |
| Order No.: | 7ME63623TE021GA2 | S/N: | N1XXXXXX | MFY: | 2026 |
| Options: | A00+E87+G05+G11+J42 | | | | |
| Process connection: | EN 1092-1, PN25 | IP67 | | | |
| Sensor material: | ASTM A 105 | | | | |
| Elec: Hastelloy C | | Size: | DN100/4" | Q3/Q1 = 40 | U0D0 |
| Tamb.: | -20°C...+55°C | Liner: | EPDM | Q3: 250m³/h | Δp 10 |
| Cal Factor: | 0.0000000 | PED/Gr.1 | All Orientation | | |
| Tmedia min/max: | 0,1...+50°C | | | | |
| MAWP (PS) at 0,1°C: | 25bar/362psi/2.5MPa | | | | |
| MAWP (PS) at 50°C: | 23.2bar/336psi/2.32MPa | | | | |
| | | | | 0200 | |
| | | | | | |
| Siemens AG, DE- 76181 Karlsruhe | | | Made in France | | |

| | | | | | |
|---------------------------------|--|--|----------------|--|--|
| SIEMENS | | | SITRANS FMS300 | | |
| | | | | | |
| Siemens AG, DE- 76181 Karlsruhe | | | Made in France | | |

Transmitter labels

| | | | | | |
|---------------------------------|---------------------|-------------------|----------------------------------|------|--|
| SIEMENS | | | SITRANS FMT020 | | |
| TRN no.: | 7ME69420AA000AA2 | S/N: | N1XXXXXX | IP67 | |
| Options: | A00+E87+G05+G11+J42 | | FW: 1.04.05 | | |
| Supply : | 12 – 42 VDC 12W | | HW: 1.00.00 | | |
| Tamb.: | -20°C...+55°C | Checksum : | 316BF639E3C41505234CA69453209EA4 | | |
| System S/N : | XXXXXXXX | System order no.: | XXXXXX | | |
| | | | | | |
| | | | | | |
| | | | 549-SITRANS_FMT020 | | |
| Siemens AG, DE- 76181 Karlsruhe | | | Made in France | | |

| | | | | | |
|---|--|--|----------------|--|--|
| SIEMENS | | | SITRANS FMT020 | | |
| Certification No.: R49/2013-A-DK2-25.01 | | | | | |
| Envir. Class: E2, O | | | | | |
| Accuracy OIML R49 Class 2 | | | | | |
| MFY: 2026 | | | | | |
| | | | | | |
| 549-SITRANS_FMT020 | | | | | |
| Siemens AG, DE- 76181 Karlsruhe | | | Made in France | | |

Security measures

Parameter protection mechanism

Device configuration

While being produced, FM320 systems will pass several parametrization operations ensuring that the match-pair system, made of a FMS300 sensor and a FMT020 transmitter can ensure CT mode, which supports metrological parameter protection mechanism.

FMS300 sensor parameter protection in SENSORPROM

During sensor production, the SENSORPROM is specifically configured for CT application.

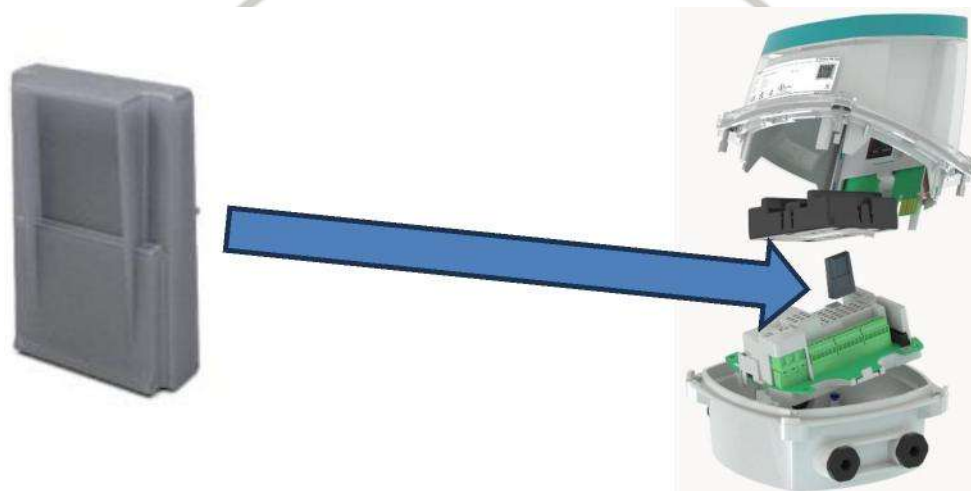

Picture 1 - Programmed SENSORPROM

FMT020 transmitter parameter protection in EEPROM

During transmitter production, the transmitter is specifically configured for CT application.



Picture 2 - FMT020 transmitter

Sealing

Internal sealing – metrological sealings

The internal sealing is carried out at factory to prevent the unauthorized dismantling of the SENSORPROM (1), containing metrological characteristics of the systems.

Another seal is applied to the CT switch and to one fixing screw of the PSU (2) to secure the position of the CT switch and to prevent the disassembly of the PSU from the terminal box.

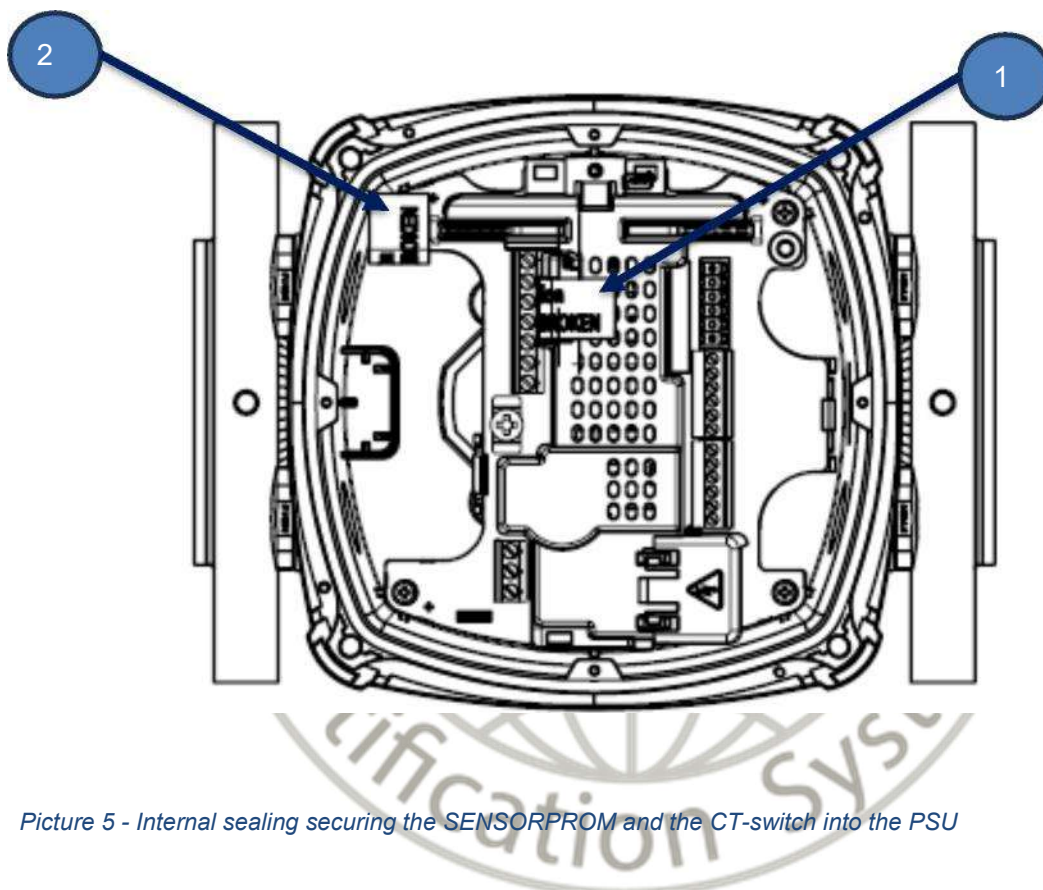

Picture 5 - Internal sealing securing the SENSORPROM and the CT-switch into the PSU

External sealing – user sealings

FM320 systems are delivered with user sealings. These user sealings are meant to be installed in the field, after commissioning, by an authorized person. These sealings prevent the opening of the enclosure and any replacement of the terminal box by an unauthorized person.

User sealing in remote operation

User sealing in remote operation consists of four seals. Two seals installed on the sensor terminal box (1) prevent access to the sensor connections. Two seals installed on the transmitter prevent unauthorized access to the electronic parts of the system.

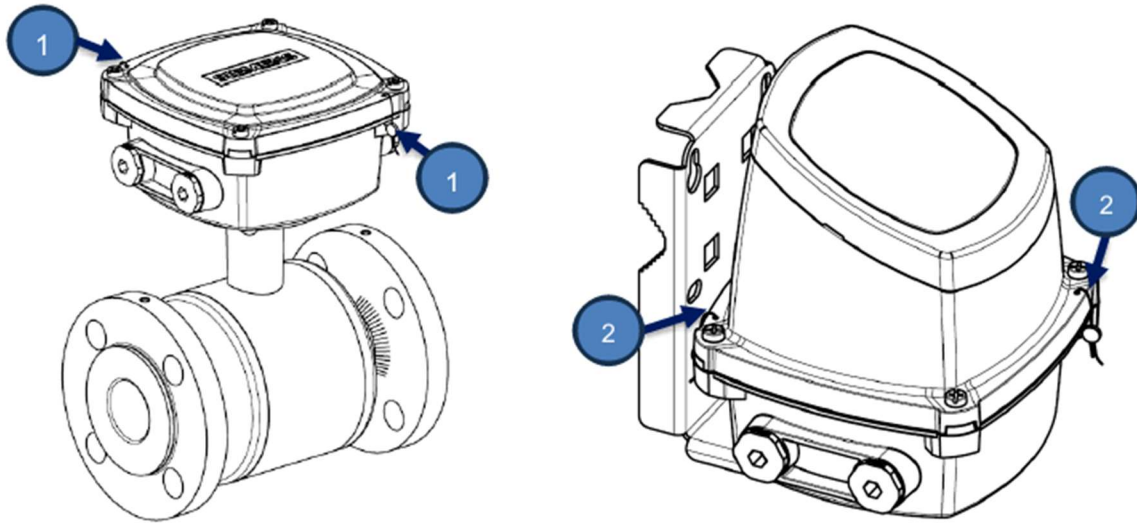

Picture 6 - User sealing in remote operation

User sealing in compact operation

User sealing in compact operation consists of two seals (3), preventing the access to the sensor connections and to the electronic parts of the system.

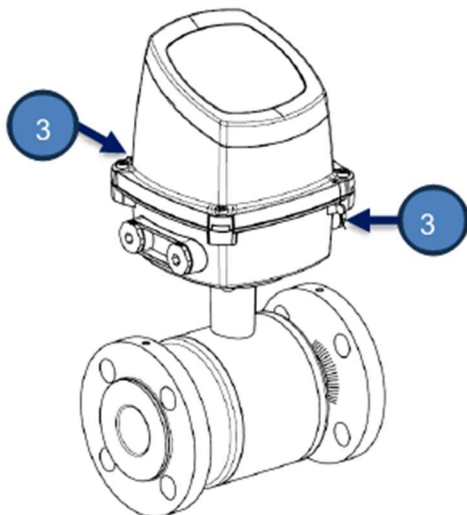

Picture 7 – User sealing in compact operation